

Well-Type Manometer

MODEL #8170

OVERVIEW

The GROTH BIOGAS Model 8170 Well-Type Manometer is a direct reading, single column type pressure gauge providing accurate pressure readings, positive, negative, or differential. It is used to indicate gas pressure in lines from the digester and those leading to utilities and waste gas burners. The GROTH BIOGAS unit may be used indoors or outdoors and is designed to be mounted almost anywhere for convenience. The GROTH BIOGAS Model 8170 may be wall mounted or panel mounted. Any number of tubes may be mounted side by side on a common panel. A solid acrylic assembly protects the shatter-proof tube and the scale against dust, dirt, and rain. GROTH BIOGAS manometers have no hidden wells or packing glands and are leak proof. The tube can be filled with a red or green oil-type liquid. The large font inch scale is easy to read. Heavy construction and durable coating provide a long-lasting product which is designed for easy cleaning and maintenance.

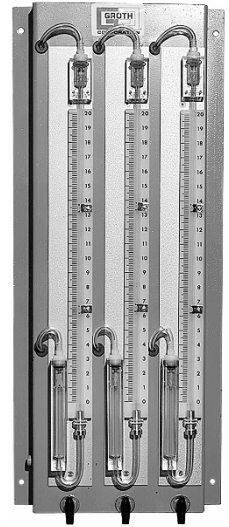

TECHNICAL DETAILS

- Scale Sizes: 12" (300 mm), 20" (500 mm), 24" (600 mm)
- Material: 14-gauge carbon steel with a corrosion resistant epoxy finish

FEATURES

- Multiple manometers are factory installed and inter-connected to simplify installation
- Each pressure port is connected to a vented stainless-steel valve for isolation and zero calibration
- All manometers are connected to a common panel vent port, and a flame check is provided for the vent line
- Wall mounting is easy, and connections are made at the bottom of the panel
- Indoor or outdoor service
- Standard, over-pressure safety traps provide absolute protection against loss of fluid

OPTIONS

- Panel or wall mounting
- Indicating oil type

SPECIFICATIONS

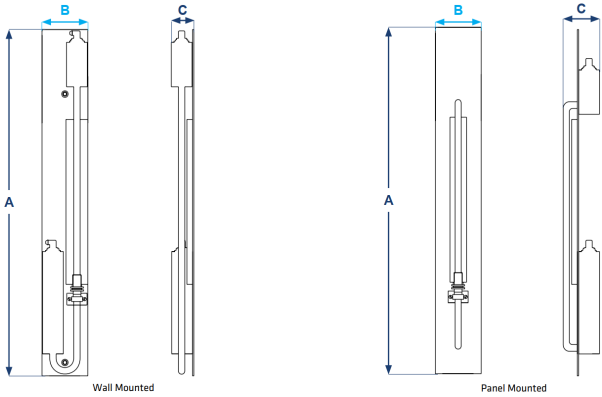

Size Inches (mm)	A Length Inches (mm)	B Height Inches (mm)	C Depth Inches (mm)	Assembly Weight LBS (KG)
12 (300)	20.88 (530)	2.75 (70)	2.50 (64)	4 (1.8)
20 (500)	29.31 (742)	2.75 (70)	2.50 (64)	5 (2.2)
24 (600)	33.56 (852)	2.75 (70)	2.50 (64)	6 (2.7)

HOW TO ORDER

M ODEL #	SIZE	MOUNTING	# Devices	OIL
<input type="text"/> <input type="text"/> <input type="text"/> <input type="text"/>	<input type="text"/> <input type="text"/>	<input type="text"/>	<input type="text"/>	<input type="text"/>
↓	↓	↓	↓	↓
8170	12" thru 24"	P = Panel W = Wall	1 = 1 Manometer 2 = 2 Manometer 3 = 3 Manometer 4 = 4 Manometer 5 = 5 Manometer 6 = 6 Manometer	1 = Green S.G 1.0 2 = Red S.G. 0826

Notes:

- Include model number when ordering
- When panel mounted any number of tubes may be mounted on a single panel with reading columns on 1.50" centers