

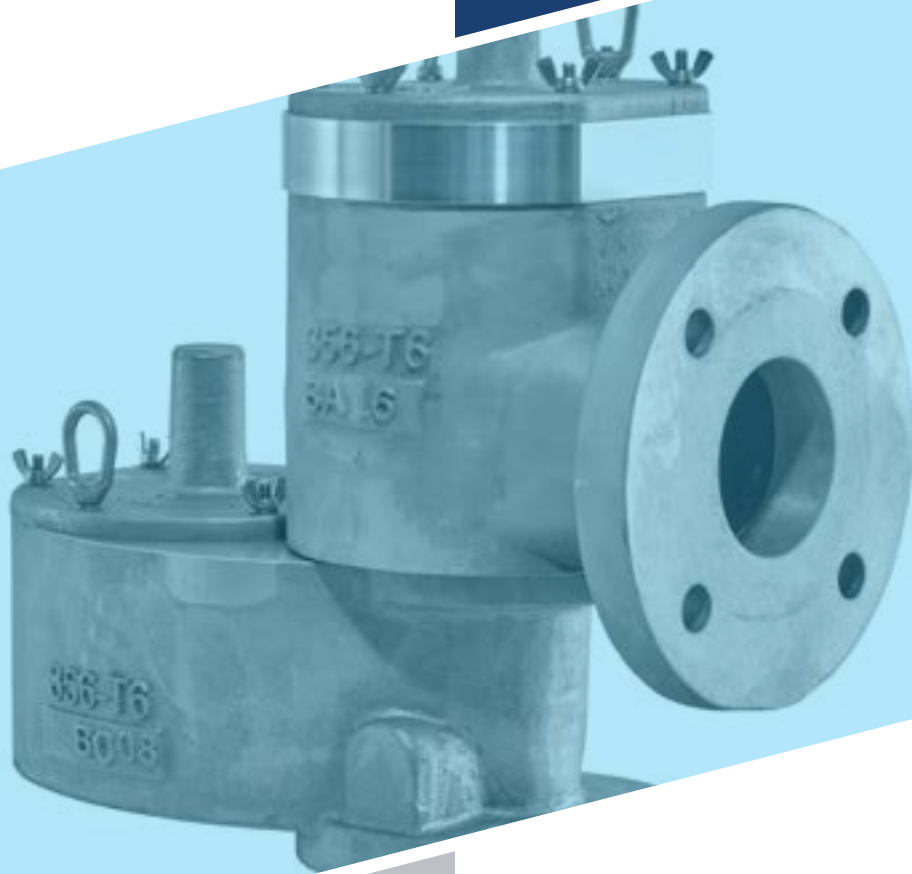

# **PRESSURE/VACUUM RELIEF VALVE**

MODEL 12F-TWW-0



# MODEL 12F-TWW-0

The Groth Model 12F-TWW-0 design was created to exceed industry needs. Extensive research and development have produced a product that achieves both superior sealing performance and industry leading flow rates, while also allowing customers to reach their required flow rates with a potentially smaller sized valve and utilize 10% overpressure technology. The pressure vacuum relief valve is designed to protect your tank from damage created by overpressure or excessive vacuum. Costly product evaporative losses due to normal tank “breathing” are greatly reduced. The Model 12F-TWW-0 are superior sealing valves developed to minimize fugitive emissions while providing increased protection and safety to tank equipment and on-site personnel.

### Technical Details

- Size: 2” through 12”
- Body Material: Aluminum, Carbon Steel, Stainless Steel
- Pallet Material: Aluminum, Stainless Steel
- Diaphragm Materials: Buna-N, Blue FKM or FEP
- Weight Material: Zinc-Plated Steel, Stainless Steel
- Bolting Class: 150# ASME, PN10, PN16, JIS drilling classes available
- Available Pressure Settings: 0.5 osig to 24 osig
- Available Vacuum Settings: 0.464 osig (2 mbarg) to 24 osig
- Superior tightness, exceeding API-2000 leak requirements
- PED and ATEX Certified

### Features

- This valve is designed to utilize 10% overpressure technology
- Product leakage and fugitive emissions are reduced via ultra-tight sealing
- Higher flow capacity to protect from both excessive pressure and excessive vacuum build up
- Peripheral and central seat guides ensure reliable, repeatable performance
- Designed for easy maintenance, thus reducing downtime and operational cost

### Options

- Corrosion resistance can be enhanced with FKM soft goods



# SPECIFICATIONS

Connection Size Inches (mm)	A Length Inches (mm)	B Height Inches (mm)	C Width Inches (mm)	D Inches (mm)	E Inches (mm)	ASSEMBLY WEIGHT *SS LBS (KG)
2x3 (50x80)	14.80 (376)	15.19 (386)	8.01 (203)	7.22 (182)	5.54 (141)	113 (51)
3x4 (80x100)	17.80 (452)	17.51 (445)	10.03 (255)	8.25 (210)	6.71 (170)	175 (79)
4x6 (100x150)	20.81 (529)	19.64 (499)	11.70 (297)	9.59 (244)	6.78 (172)	256 (116)
6x8 (150x200)	27.98 (711)	25.58 (650)	14.91 (379)	12.87 (327)	8.78 (222)	457 (207)
8x10 (200x250)	35.55 (903)	30.36 (771)	18.06 (459)	15.37 (390)	11.17 (284)	714 (324)
10x12 (250x300)	41.89 (1064)	35.62 (905)	19.63 (499)	18.14 (461)	12.91 (328)	978 (444)
12x14 (300x350)	48.52 (1232)	39.15 (994)	25.56 (649)	20.68 (525)	15.06 (383)	1330 (603)

Assembly weight is based on minimum pressure settings.

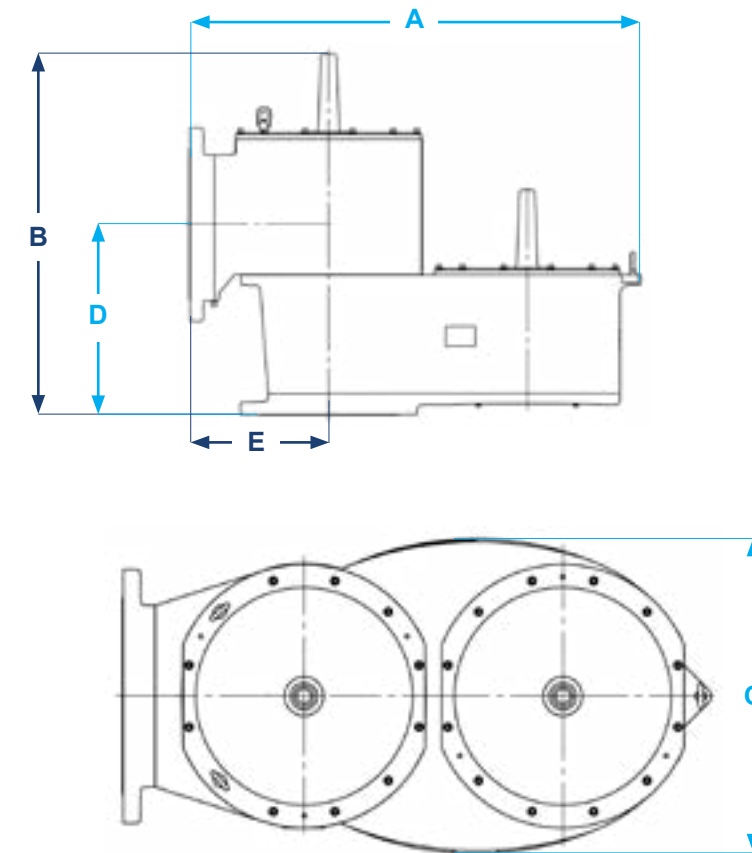

# FLOW CAPACITY

Model: 12F-TWW-o Pressure Flow Capacity

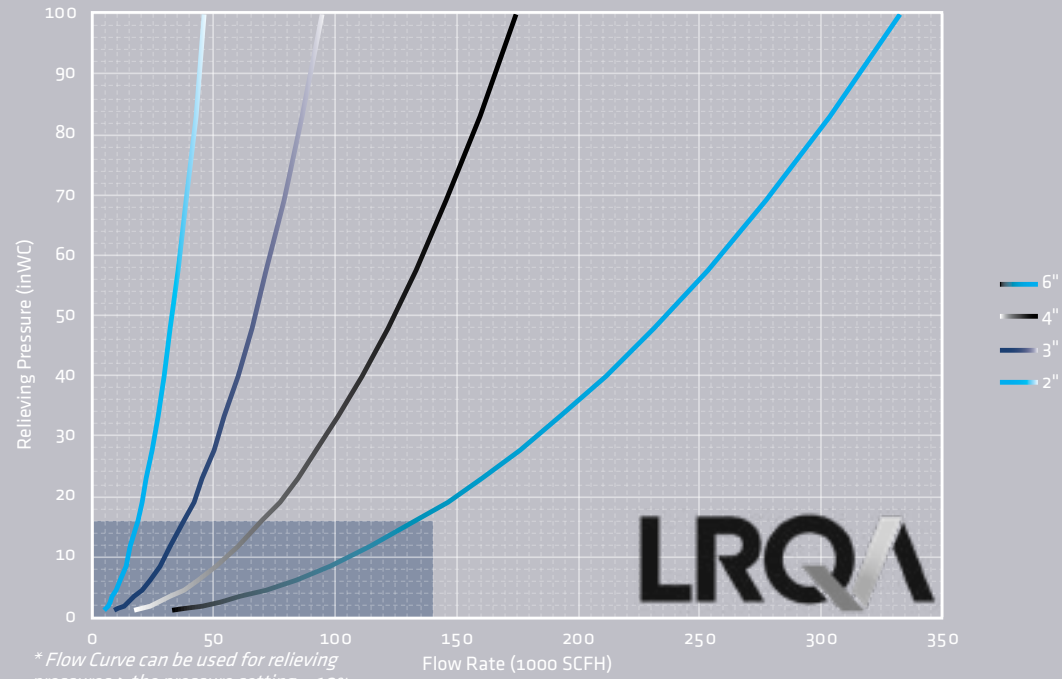

# FLOW CAPACITY

Model: 12F-TWW-o Pressure Flow Capacity

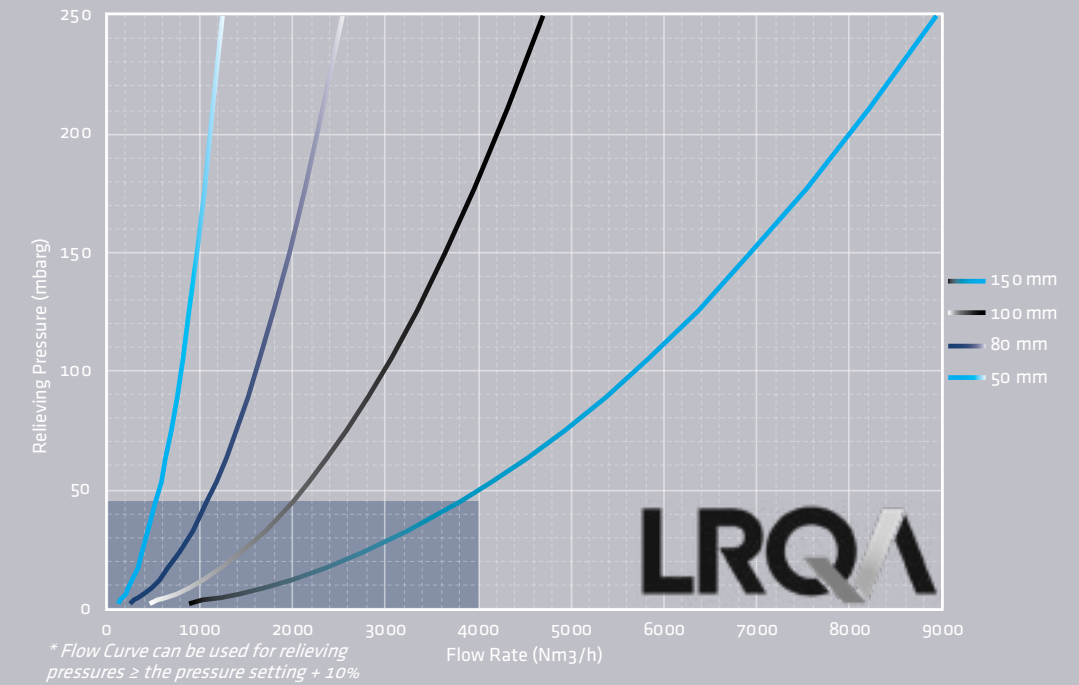

Model: 12F-TWW-o Pressure Flow Capacity

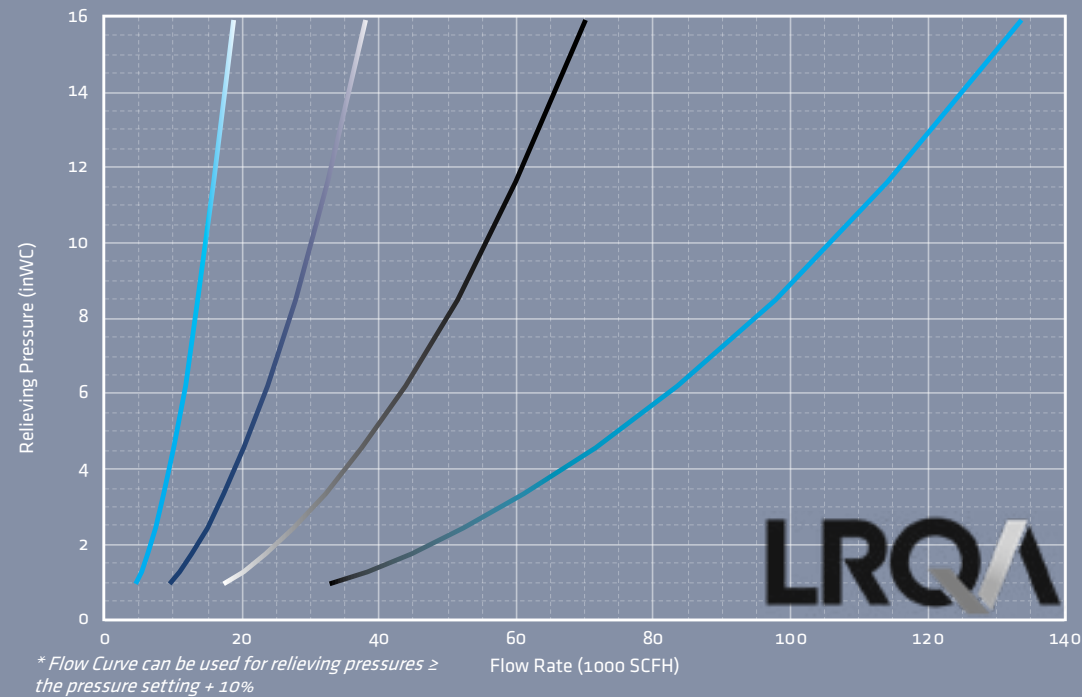

Model: 12F-TWW-o Pressure Flow Capacity

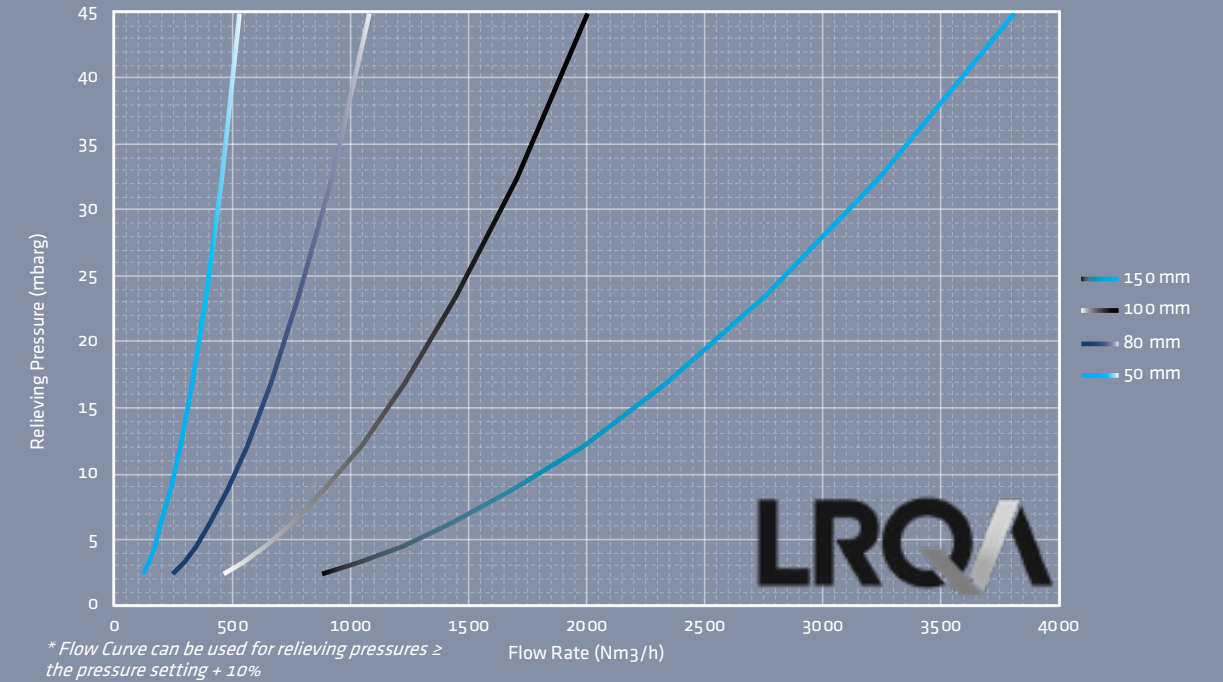

- The test equipment, procedures, and reporting methods utilized by Groth Corporation meet the requirements of standards API 2000/ISO 28300. The equipment, methods, and results have been reviewed and certified by Lloyds.
- Flow data are for tank mounting or end-of-line and includes entrance loss, exit loss and internal losses.
- Flow values based on air at 60°F venting to atmospheric pressure of 14.6959 psia.

- The test equipment, procedures, and reporting methods utilized by Groth Corporation meet the requirements of standards API 2000/ISO 28300. The equipment, methods, and results have been reviewed and certified by Lloyds.
- Flow data are for tank mounting or end-of-line and includes entrance loss, exit loss and internal losses.
- Flow values based on air at 0°C venting to atmospheric pressure of 1.01325 bara.

# FLOW CAPACITY

Model: 12F-TWW-o Pressure Flow Capacity

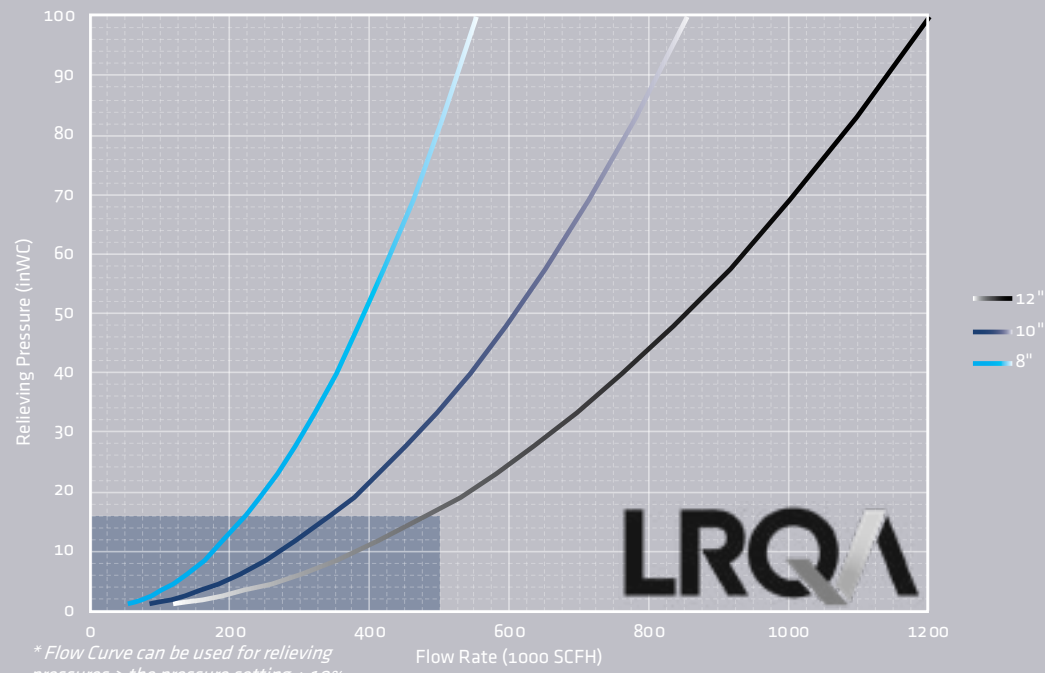

# FLOW CAPACITY

Model: 12F-TWW-o Pressure Flow Capacity

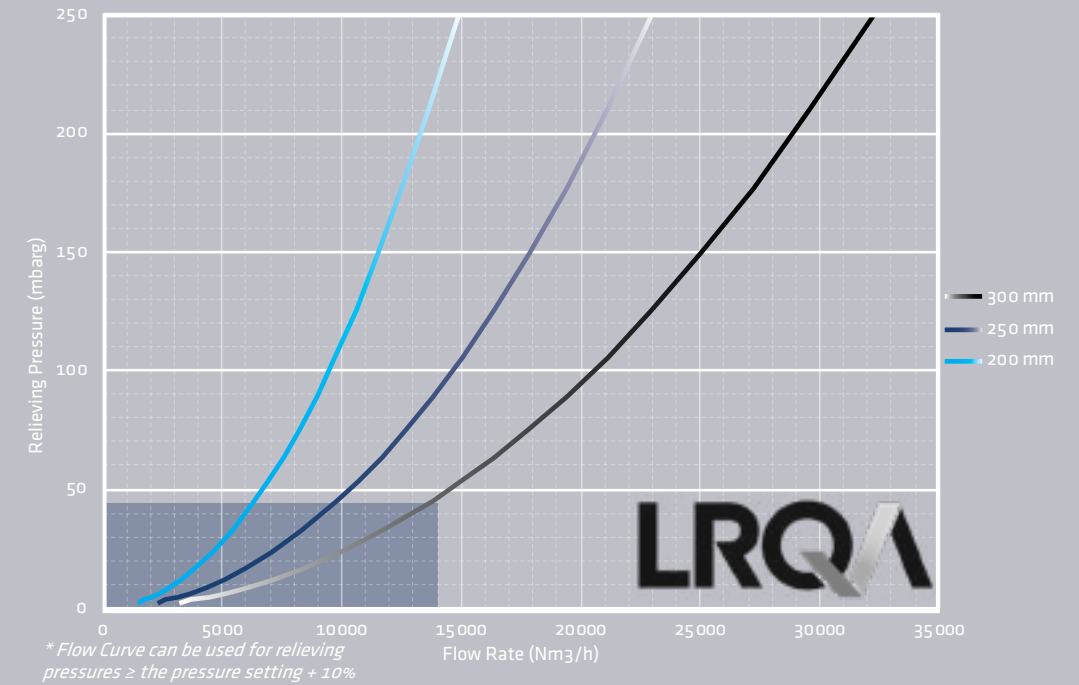

Model: 12F-TWW-o Pressure Flow Capacity

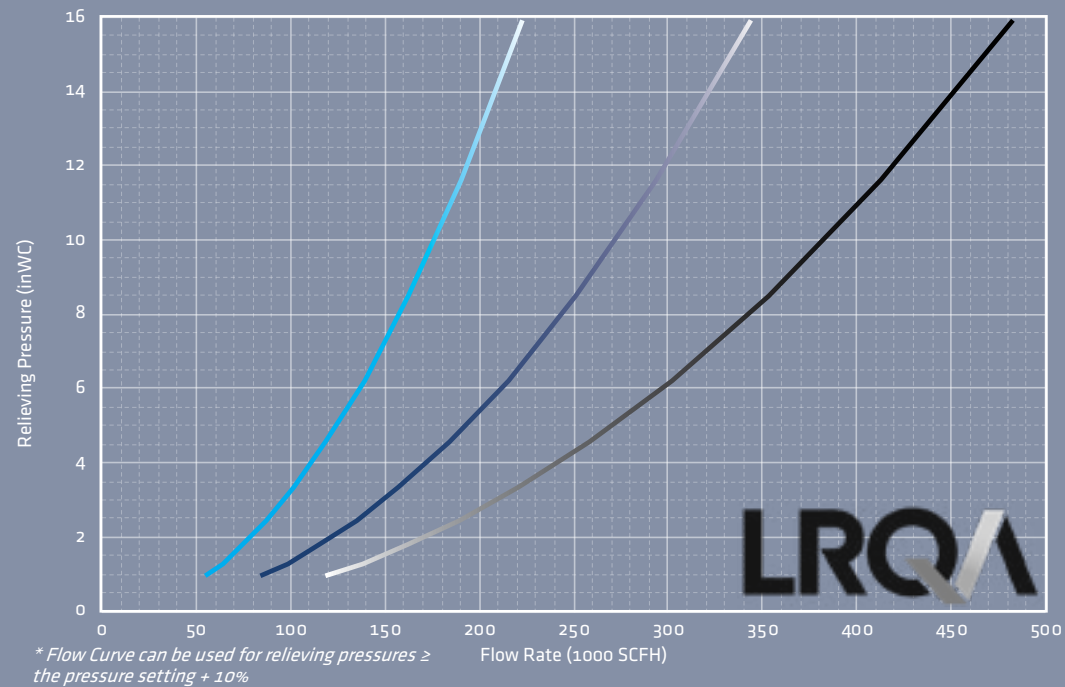

Model: 12F-TWW-o Pressure Flow Capacity

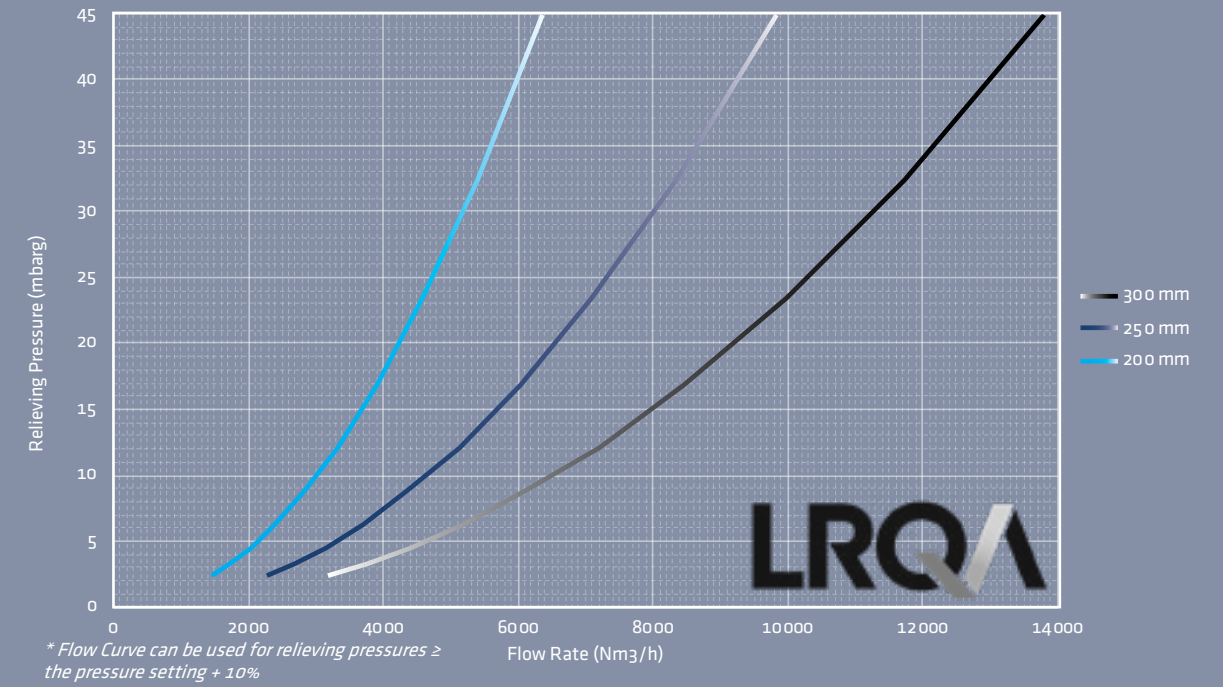

- The test equipment, procedures, and reporting methods utilized by Groth Corporation meet the requirements of standards API 2000/ISO 28300. The equipment, methods, and results have been reviewed and certified by Lloyds.
- Flow data are for tank mounting or end-of-line and includes entrance loss, exit loss and internal losses.
- Flow values based on air at 60°F venting to atmospheric pressure of 14.6959 psia.

- The test equipment, procedures, and reporting methods utilized by Groth Corporation meet the requirements of standards API 2000/ISO 28300. The equipment, methods, and results have been reviewed and certified by Lloyds.
- Flow data are for tank mounting or end-of-line and includes entrance loss, exit loss and internal losses.
- Flow values based on air at 0°C venting to atmospheric pressure of 1.01325 bara.

# FLOW CAPACITY

Model: 12F-TWW-o Vacuum Flow Capacity

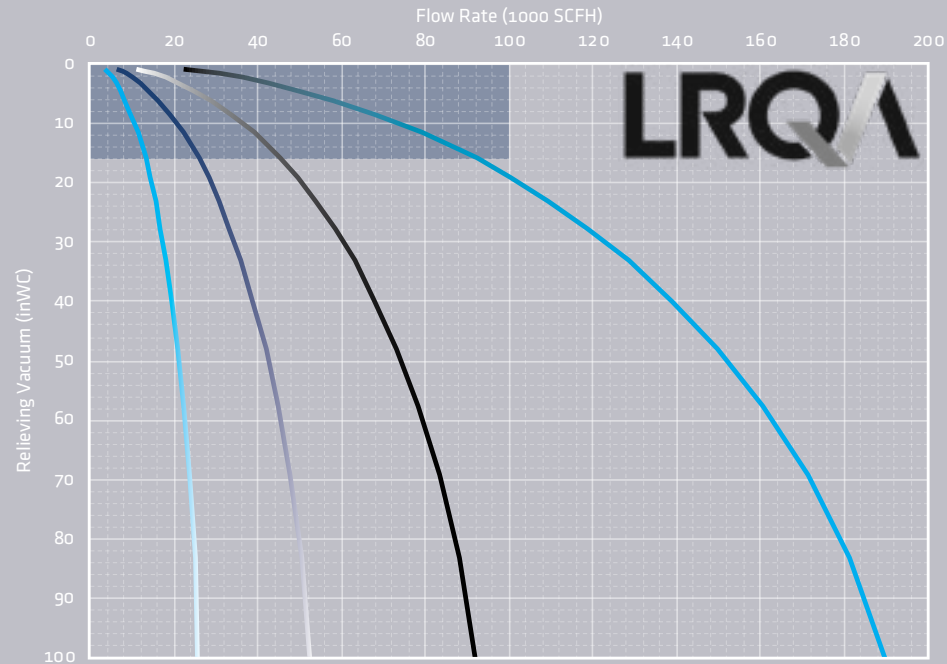

\* Flow Curve based on the relieving vacuum being equal to the vacuum setting + 10%

# FLOW CAPACITY

Model: 12F-TWW-o Vacuum Flow Capacity

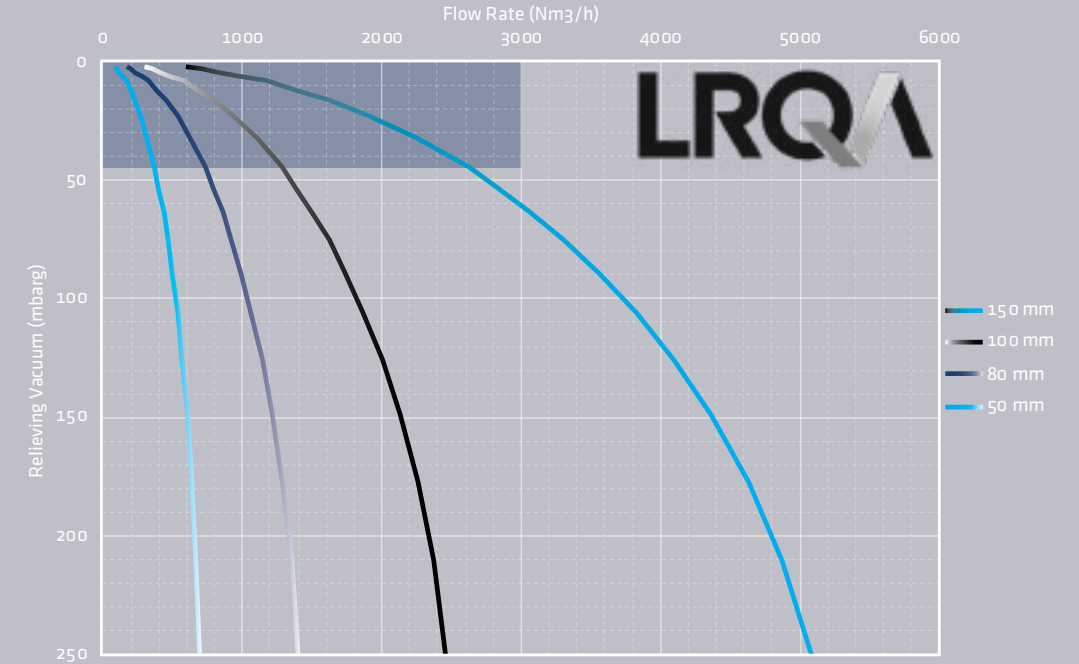

\* Flow Curve based on the relieving vacuum being equal to the vacuum setting + 10%

Model: 12F-TWW-o Vacuum Flow Capacity

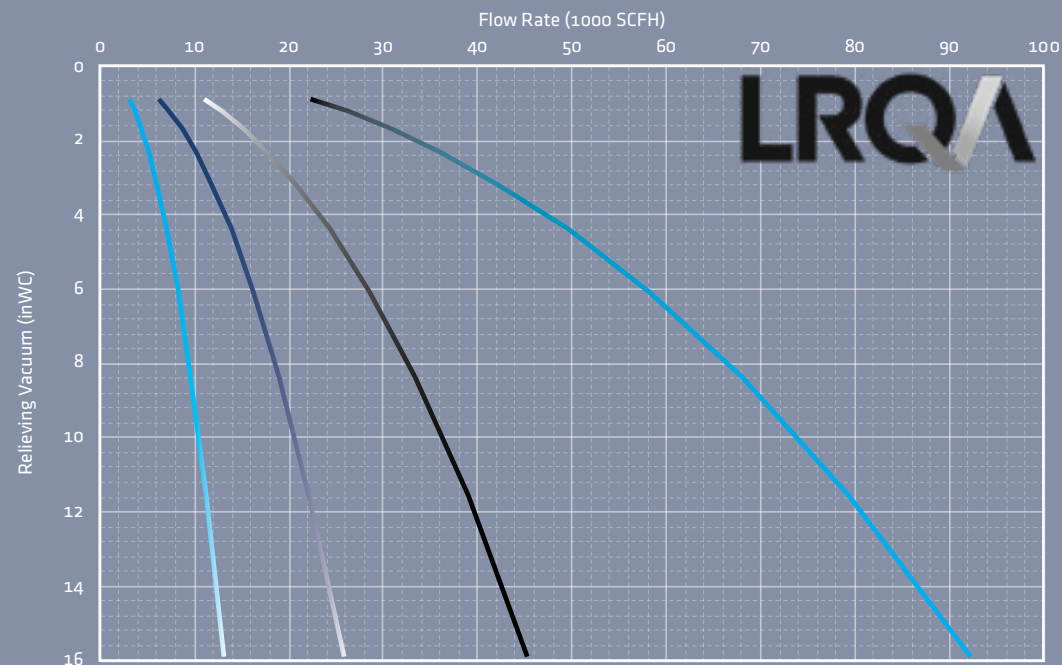

\* Flow Curve based on the relieving vacuum being equal to the vacuum setting + 10%

Model: 12F-TWW-o Vacuum Flow Capacity

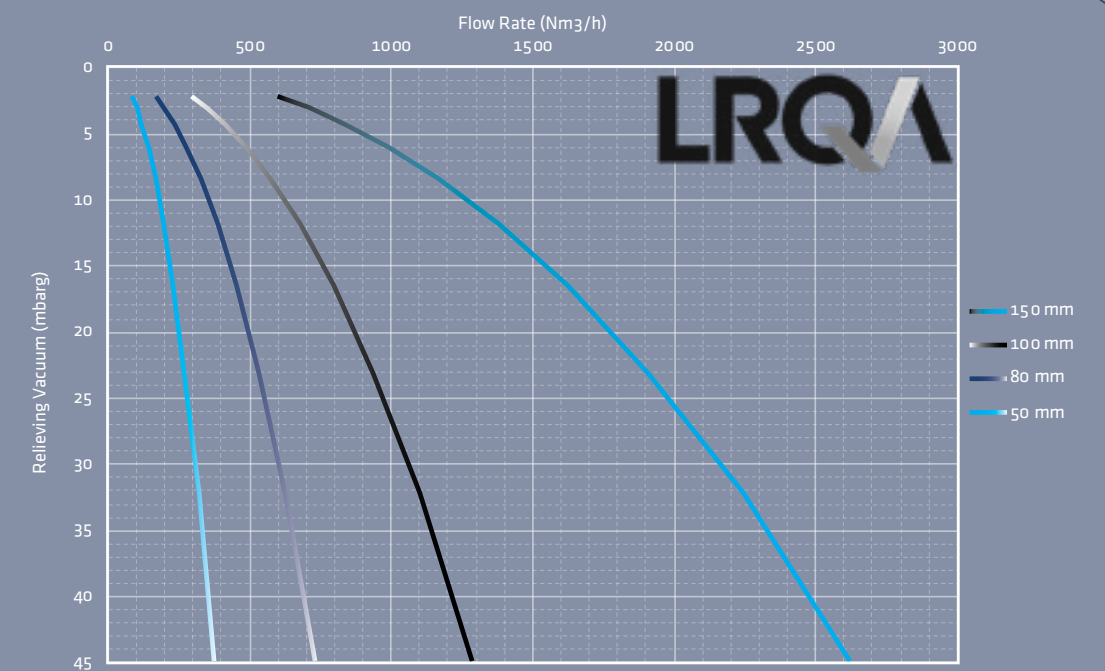

\* Flow Curve based on the relieving vacuum being equal to the vacuum setting + 10%

- The test equipment, procedures, and reporting methods utilized by Groth Corporation meet the requirements of standards API 2000/ISO 28300. The equipment, methods, and results have been reviewed and certified by Lloyds.
- Flow data are for tank mounting or end-of-line and includes entrance loss, exit loss and internal losses.
- Flow values based on air at 60°F venting from atmospheric pressure of 14.6959 psia.

- The test equipment, procedures, and reporting methods utilized by Groth Corporation meet the requirements of standards API 2000/ISO 28300. The equipment, methods, and results have been reviewed and certified by Lloyds.
- Flow data are for tank mounting or end-of-line and includes entrance loss, exit loss and internal losses.
- Flow values based on air at 0°C venting from atmospheric pressure of 1.01325 bara.

# FLOW CAPACITY

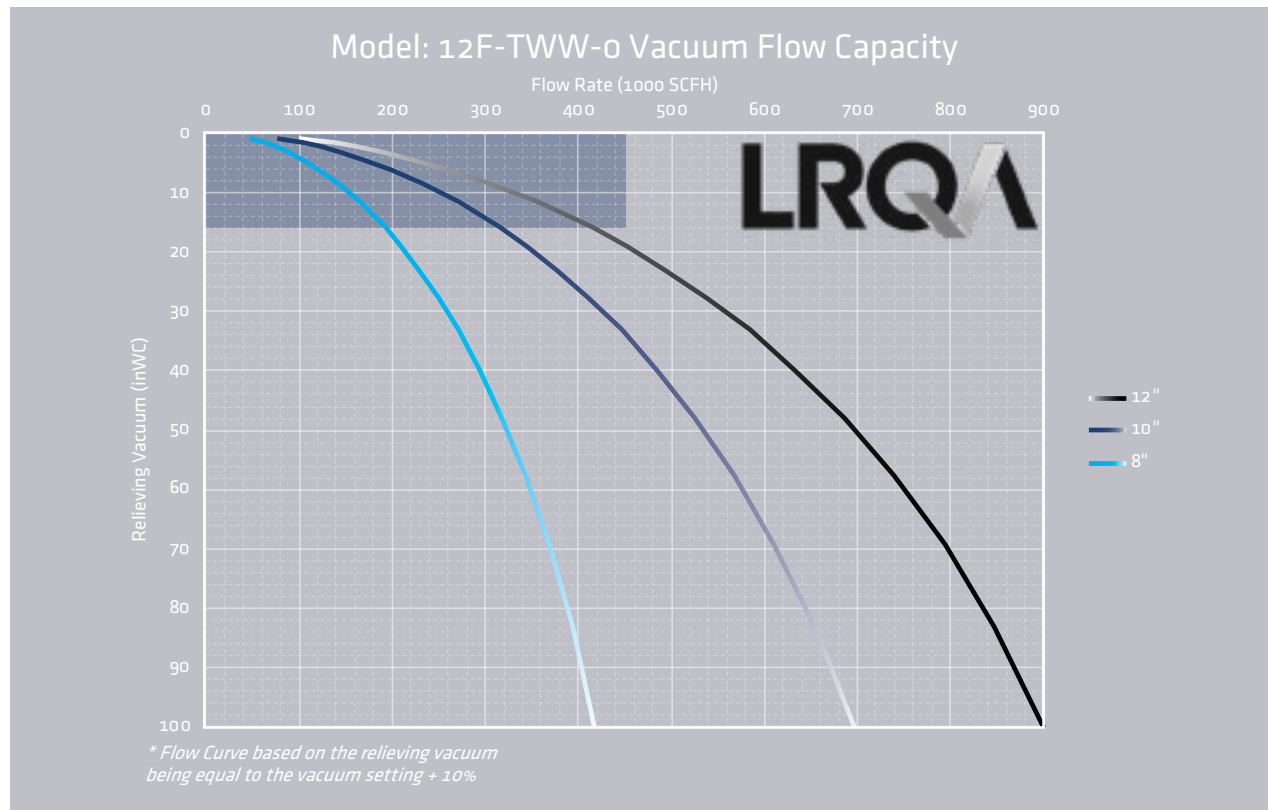

# FLOW CAPACITY

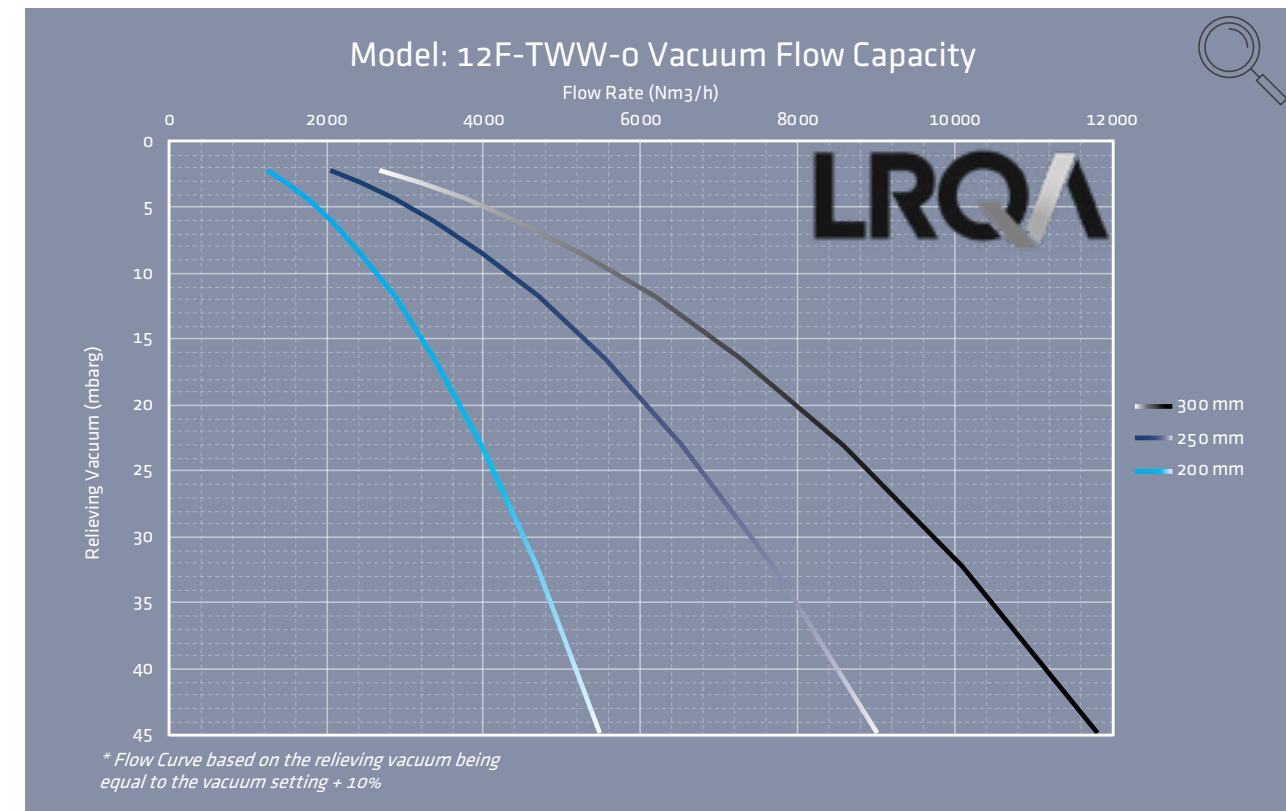
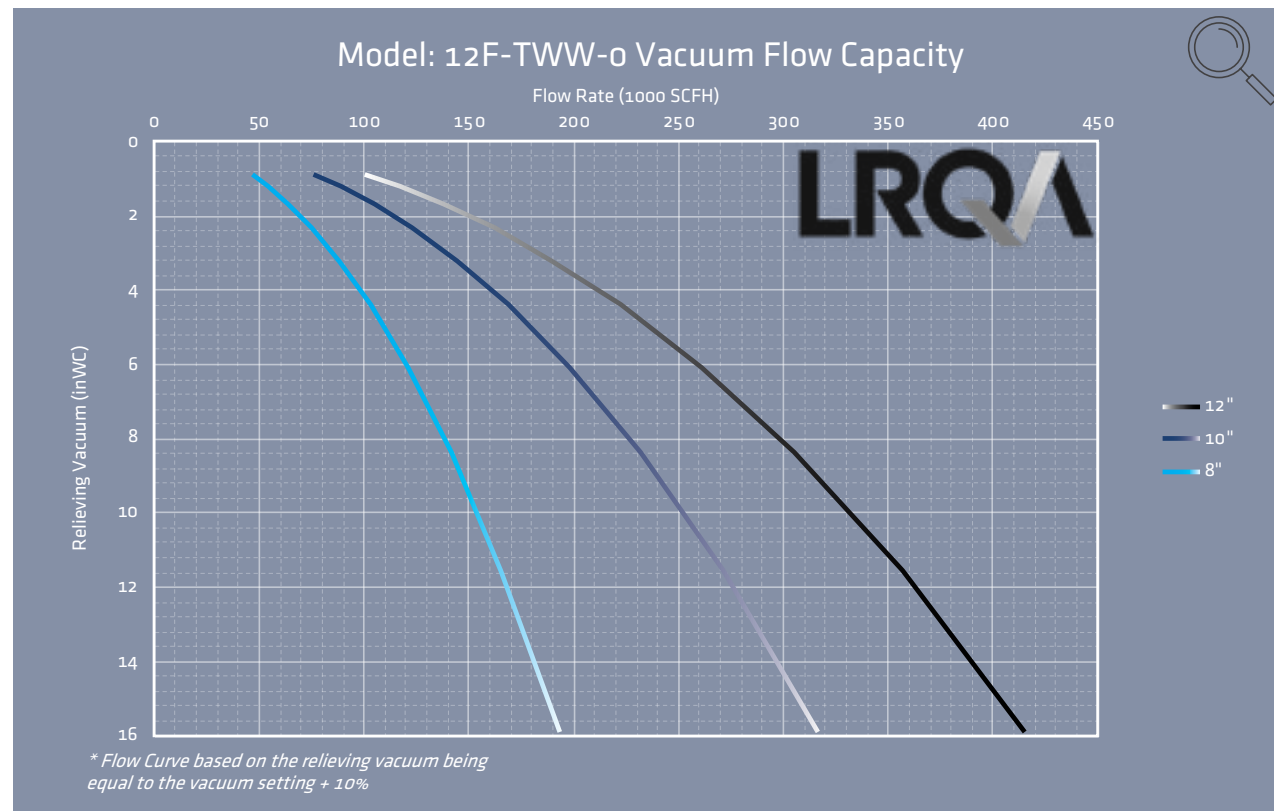
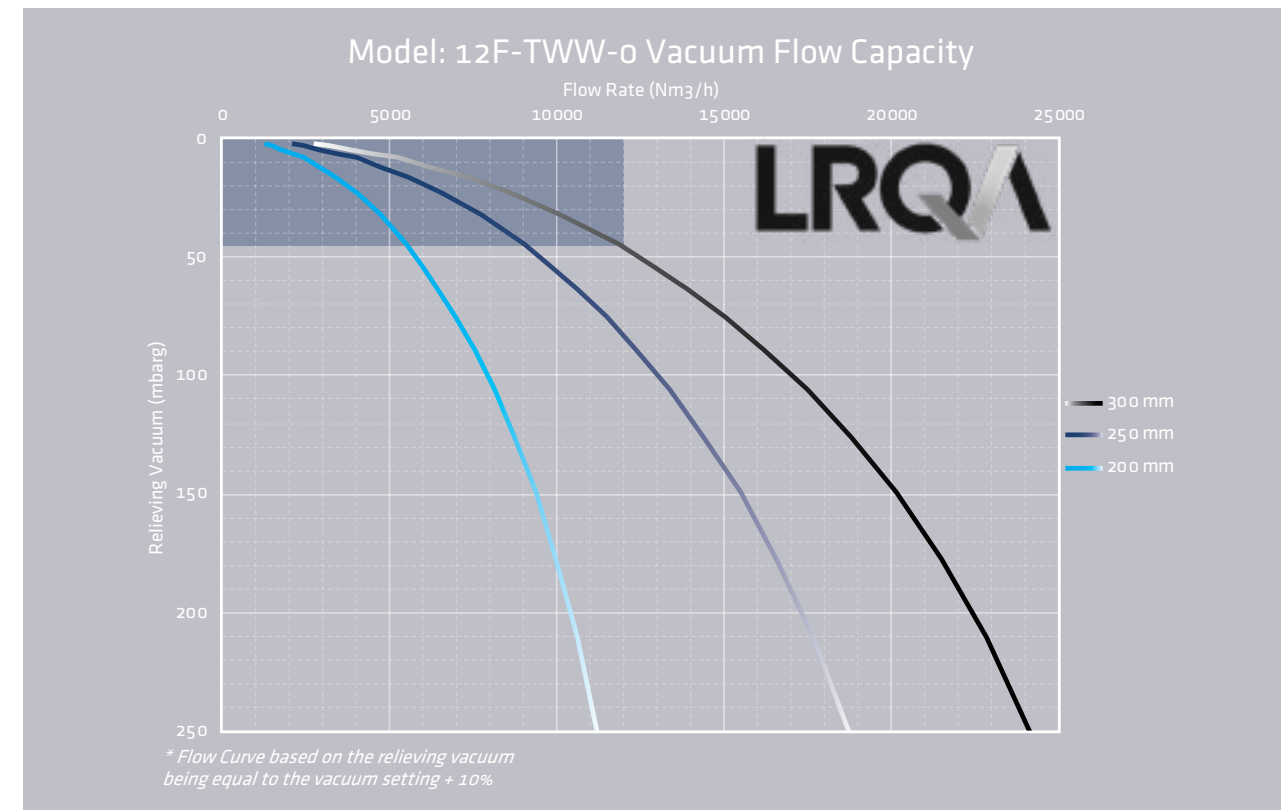

- The test equipment, procedures, and reporting methods utilized by Groth Corporation meet the requirements of standards API 2000/ISO 28300. The equipment, methods, and results have been reviewed and certified by Lloyds.
- Flow data are for tank mounting or end-of-line and includes entrance loss, exit loss and internal losses.
- Flow values based on air at 60°F venting from atmospheric pressure of 14.6959 psia.

- The test equipment, procedures, and reporting methods utilized by Groth Corporation meet the requirements of standards API 2000/ISO 28300. The equipment, methods, and results have been reviewed and certified by Lloyds.
- Flow data are for tank mounting or end-of-line and includes entrance loss, exit loss and internal losses.
- Flow values based on air at 0°C venting from atmospheric pressure of 1.01325 bara.

# HOW TO ORDER

For easy ordering, select proper model numbers

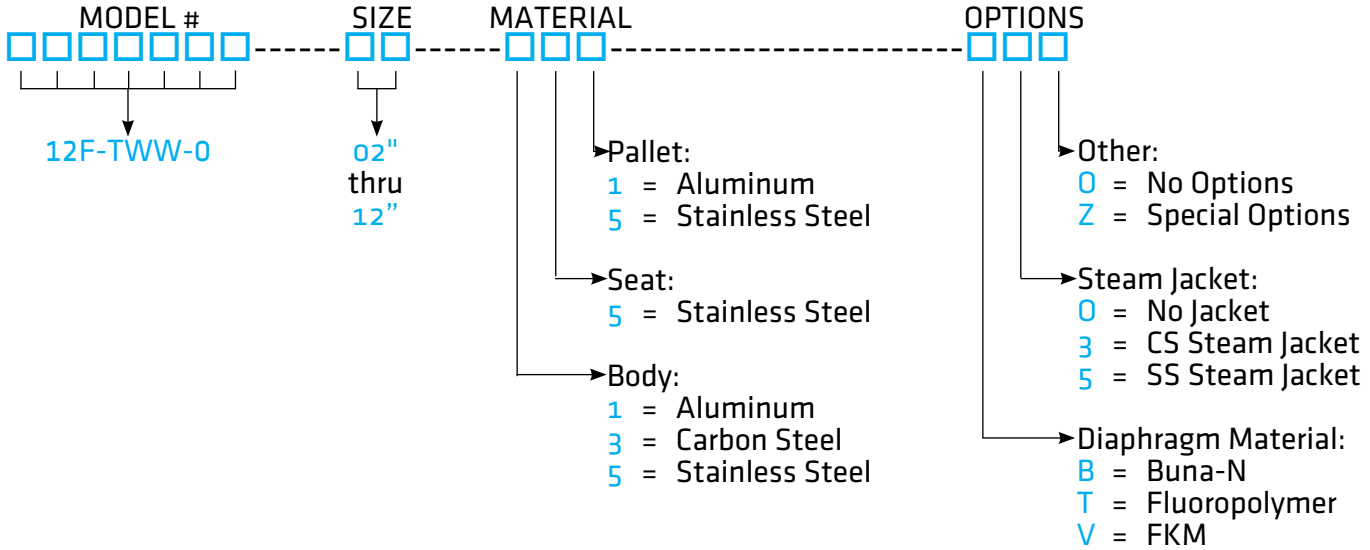

## Notes

- Include model number and setting when ordering.
- For special options, consult factory.



[GROTHCORP.COM](http://GROTHCORP.COM)