

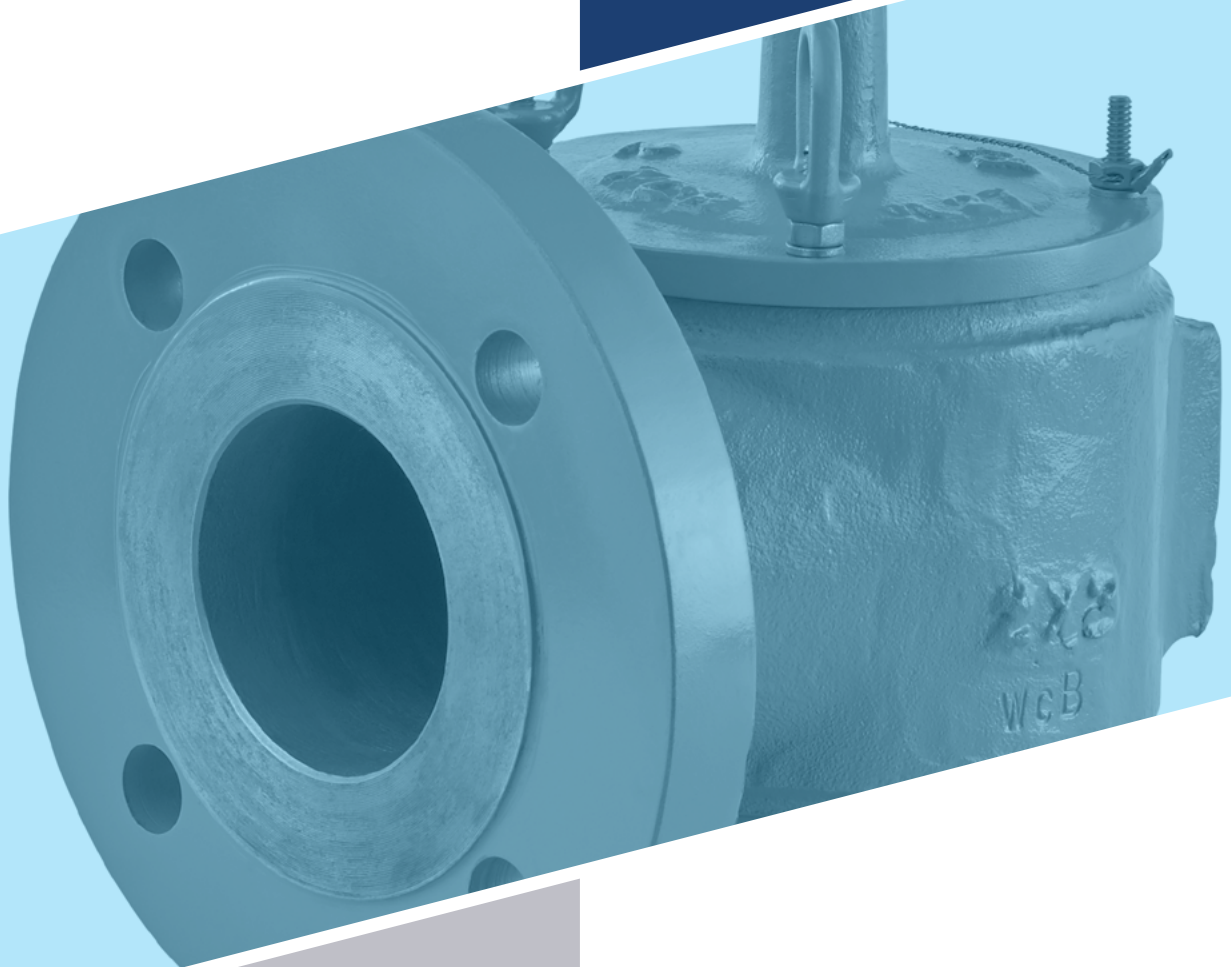

PRESSURE RELIEF VALVES

MODELS 1260A & 1261A



MODELS 1260A & 1261A

The Groth Models 1260A & 1261A Pressure Relief Valves are designed to protect your tank from damage created by overpressure or excessive vacuum. Costly product evaporation losses due to normal tank “breathing” are greatly reduced. Because the 1200 Series products retain toxic vapors, atmospheric contamination is minimized which helps to provide increased fire protection and safety.

Technical Details

- Sizes: 2” (DN 50) through 12” (DN 300)
- Pressure Settings: 0.5 oz/in² to 15 psig (2.15 mbarg to 1.03 barg)
- Vacuum Settings: 0.5 oz/in² to 12 psig (2.15 mbarg to 506 mbarg)
- Material: Aluminum, Carbon Steel, Stainless Steel, Fiberglass, special materials available upon request

Features

- Modular Construction
- Cushioned air seating
- Superior performing fluoropolymer diaphragms
- Self draining housing body and drip rings
- Peripheral Guiding and center stabilizing system for alignment
- PED and ATEX Certified

Options

- Buna-N, FKM
- Steam Jacket Valve



1260A



1261A

SPECIFICATIONS

Inlet Flg ^o In (mm)	Outlet Flg ^o In (mm)	Max. Set Pressure Weight Loaded oz/in ² (gm/cm ²)	Max. Setting Spring Loaded	Min. Setting Weight Loaded	A Length In (mm)	B Height In (mm)	C Width In (mm)	D In (mm)	E In (mm)	BB In (mm)	Approx. Ship Wt. for Al Lbs (kg)
2 (50)	3 (76)	11 (48.3)	15 psig Spring Loaded Pressure (1.05 kg/cm ²)	* 0.5 oz/in ² Weight Loaded (2.20 gm/cm ²)	8.62 (219)	9.37 (238)	7.50 (191)	4.12 (105)	5.50 (140)	16.62 (4222)	16 (7)
3 (80)	4 (102)	13 (57.1)			10 (254)	11.12 (282)	9 (229)	5 (127)	6 (152)	20.25 (514)	22 (10)
4 (100)	6 (152)	16 (70.3)			11 (279)	13.87 (352)	11 (279)	6.50 (165)	6.50 (165)	25.62 (651)	29 (13)
6 (150)	8 (203)	16 (70.3)			14.50 (368)	17.37 (441)	13.5 (343)	8.50 (216)	8.50 (216)	34.50 (876)	55 (25)
8 (200)	10 (254)	16 (70.3)			18 (457)	21.25 (540)	16 (406)	9.75 (248)	10.75 (273)	39.75 (1010)	92 (42)
10 (250)	12 (305)	16 (70.3)			20.75 (527)	23.62 (600)	19 (483)	10.25 (260)	12.50 (318)	46.37 (1178)	105 (48)
12 (300)	14 (356)	16 (70.3)			24.75 (629)	26.62 (676)	21 (533)	11 (279)	15 (381)	49.25 (1251)	149 (68)

[‡] On spring loaded valves, change model number. ^o 150# R.F. drilling compatibility F.F. on aluminum and R.F. on carbon steel and stainless steel alloys. Fiberglass dimensions on request. 16 oz/in² set with spacer. 55 set weights-consult factory. *Some sizes require non-ferrous components to achieve 0.5 oz/in² setting

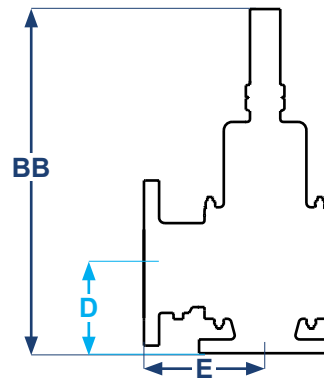
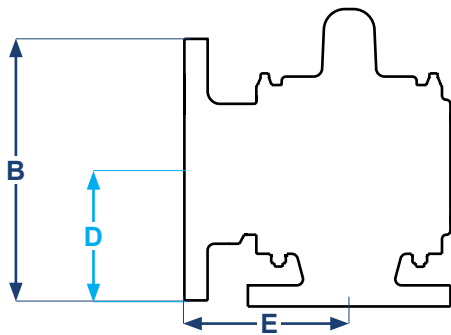
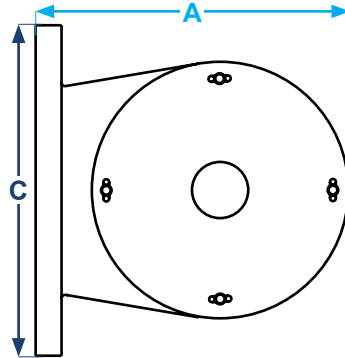

MODEL 1260A PRESSURE RELIEF CAPACITY

Air Flow Capacity at 100% Overpressure (Double Set Pressure)
1000 Standard Cubic Feet per Hour at 60° F

Set Pressure (P _s)		Size In (mm)						
InWC	oz/in ²	2 (50)	3 (80)	4 (100)	6 (150)	8 (200)	10 (250)	12 (300)
0.87	0.50	6.87	13.3	25.2	52.7	82.6	135	175
1.00	0.58	7.39	14.3	27.1	56.6	88.8	145	188
1.73	1.00	9.71	18.8	35.6	74.3	117	190	247
2.00	1.16	10.4	20.2	38.2	79.8	125	205	265
2.60	1.50	11.9	23.0	43.5	90.8	143	233	302
3.00	1.73	12.8	24.7	46.8	97.5	153	250	324
3.46	2.00	13.7	26.6	50.2	105	164	268	348
4.00	2.31	14.7	28.6	53.9	112	177	288	374
6.00	3.47	18.0	35.0	65.9	137	215	351	456
8.00	4.62	20.7	40.4	75.8	157	248	404	525
10.0	5.78	23.1	45.1	84.6	175	276	450	584
12.0	6.93	25.2	49.4	92.4	191	301	491	638
15.0	8.66	28.1	55.2	103	211	335	546	709
20.0	11.6	32.2	63.7	118	241	383	625	811
25.0	14.4	35.8	71.2	131	267	424	692	898
30.0	17.3	39.0	77.9	143	289	460	751	975

Flow Capacity Calculation

Flow capacity values listed above are based on full open valves at 100% overpressure. Read the flow capacity at 100% overpressure directly from the table above. Use linear std. If the allowable overpressure is less than 100%, modify the flow capacity using the appropriate "C" factor from the table. If allowable overpressure is more than 100%, consult your Groth Representative.

Calculate the percentage overpressure by the following formula. Note that all pressures are gauge pressure expressed in the same units of measure.

$$P_f = \text{Flowing pressure}$$

$$P_s = \text{Set pressure}$$

$$\% \text{ OP} = [(P_f - P_s) / P_s] \times 100$$

Calculate flow capacity at less than 100% overpressure according to the following example.

Example Flow Capacity Calculation

6" Model 1260A

4 InWC set pressure [P_s]

7 InWC flowing pressure [P_f]

1. Read flow capacity at set pressure from table Flow = 112,000 SCFH
2. Calculate overpressure % OP = [(7 - 4) / 4] x 100 = 75%
3. Read "C" factor from table "C" = 0.87
4. Calculate flow capacity Flow = 0.87 x 112,000 = 97,440 SCFH

"C" Factor Table

%OP	0	1	2	3	4	5	6	7	8	9
10	0.42	0.43	0.44	0.45	0.46	0.46	0.47	0.48	0.49	0.50
20	0.51	0.52	0.52	0.53	0.54	0.55	0.56	0.56	0.57	0.58
30	0.59	0.59	0.60	0.61	0.61	0.62	0.63	0.64	0.64	0.65
40	0.66	0.66	0.67	0.68	0.68	0.69	0.70	0.70	0.71	0.72
50	0.72	0.73	0.73	0.74	0.75	0.75	0.76	0.77	0.77	0.78
60	0.78	0.79	0.80	0.80	0.81	0.81	0.82	0.82	0.83	0.84
70	0.84	0.85	0.85	0.86	0.86	0.87	0.88	0.88	0.89	0.89
80	0.90	0.90	0.91	0.91	0.92	0.92	0.93	0.93	0.94	0.94
90	0.95	0.95	0.96	0.96	0.97	0.97	0.98	0.99	0.99	1.00

Example to find "C" factor from table:

Read "C" factor for 75% overpressure at intersection of row 70 and column 5

"C" factor at 75% OP = 0.87

MODEL 1260A PRESSURE RELIEF CAPACITY

Air Flow Capacity at 100% Overpressure (Double Set Pressure)
1000 Normal Cubic Meters per Hour at 0° C

Set Pressure (P _s)		Size In (mm)						
mmWC	mb	2 (50)	3 (80)	4 (100)	6 (150)	8 (200)	10 (250)	12 (300)
22	2.16	0.19	0.37	0.71	1.48	2.33	3.80	4.93
50	4.90	0.29	0.56	1.07	2.23	3.50	5.72	7.42
75	7.35	0.36	0.69	1.31	2.72	4.28	6.99	9.10
100	9.80	0.41	0.80	1.51	3.14	4.93	8.05	10.4
125	12.3	0.46	0.89	1.68	3.50	5.51	8.99	11.7
150	14.7	0.50	0.98	1.84	3.82	6.02	9.80	12.7
175	17.2	0.54	1.06	1.99	4.12	6.49	10.6	13.7
200	19.6	0.58	1.13	2.12	4.39	6.92	11.3	14.7
225	22.1	0.61	1.20	2.25	4.65	7.33	12.0	15.5
250	24.5	0.65	1.26	2.36	4.89	7.71	12.6	16.3
275	27.0	0.68	1.32	2.48	5.11	8.07	13.2	17.1
300	29.4	0.70	1.38	2.58	5.33	8.42	13.7	17.8
375	36.8	0.78	1.54	2.88	5.91	9.40	15.3	19.8
500	49.0	0.90	1.78	3.30	6.75	10.7	17.5	22.7
625	61.3	1.00	1.99	3.67	7.46	11.9	19.4	25.1
750	73.5	1.09	2.18	3.99	8.07	12.9	21.0	27.3

Flow Capacity Calculation

Flow capacity values listed above are based on full open valves at 100% overpressure. Read the flow capacity at 100% overpressure directly from the table above. Use linear interpolation if the set pressure is not listed. If the allowable overpressure is less than 100%, modify the flow capacity using the appropriate "C" factor from the table. If allowable overpressure is more than 100%, consult your Groth Representative.

Calculate the percentage overpressure by the following formula. Note that all pressures are gauge pressure expressed in the same units of measure.

Pf = Flowing pressure

Ps = Set pressure

$$\% \text{ OP} = [(P_f - P_s) / P_s] \times 100$$

Calculate flow capacity at less than 100% overpressure according to the following example.

Example Flow Capacity Calculation

6" Model 1260A

100 mmWC Set Pressure [P_s]

175 mmWC Flowing Pressure [P_f]

1. Read flow capacity at set pressure from table Flow = 3,140 NCMH

2. Calculate overpressure

$$\% \text{ OP} = [(175 - 100) / 100] \times 100 = 75\%$$

3. Read "C" factor from table

$$\text{"C"} = 0.87$$

4. Calculate flow capacity

$$\text{Flow} = 0.87 \times 3,140 = 2,732 \text{ NCMH}$$

"C" Factor Table

%OP	0	1	2	3	4	5	6	7	8	9
10	0.42	0.43	0.44	0.45	0.46	0.46	0.47	0.48	0.49	0.50
20	0.51	0.52	0.52	0.53	0.54	0.55	0.56	0.56	0.57	0.58
30	0.59	0.59	0.60	0.61	0.61	0.62	0.63	0.64	0.64	0.65
40	0.66	0.66	0.67	0.68	0.68	0.69	0.70	0.70	0.71	0.72
50	0.72	0.73	0.73	0.74	0.75	0.75	0.76	0.77	0.77	0.78
60	0.78	0.79	0.80	0.80	0.81	0.81	0.82	0.82	0.83	0.84
70	0.84	0.85	0.85	0.86	0.86	0.87	0.88	0.88	0.89	0.89
80	0.90	0.90	0.91	0.91	0.92	0.92	0.93	0.93	0.94	0.94
90	0.95	0.95	0.96	0.96	0.97	0.97	0.98	0.99	0.99	1.00

Example to find "C" factor from table:

Read "C" factor for 75% overpressure at intersection of row 70 and column 5

"C" factor at 75% OP = 0.87

MODEL 1261A PRESSURE RELIEF CAPACITY

Air Flow Capacity at 100% Overpressure (Double Set Pressure)
1000 Standard Cubic Feet per Hour at 60° F

Set Pressure (P _s)	Size In (mm)						
psig	2 (50)	3 (80)	4 (100)	6 (150)	8 (200)	10 (250)	12 (300)
1.00	28.0	53.4	92.5	210	345	529	739
2.00	40.3	77.4	134	304	500	767	1070
3.00	50.2	96.9	168	381	625	960	1340
4.00	58.8	114	198	448	736	1130	1577
5.00	66.5	130	225	510	838	1286	1794
6.00	73.7	144	250	568	932	1431	1997
7.00	80.4	158	274	622	1022	1568	2188
8.00	86.7	171	297	674	1107	1699	2371
9.00	92.8	184	319	724	1189	1825	2546
10.0	98.6	196	340	772	1267	1945	2714
11.0	104	208	360	818	1343	2062	2877
12.0	110	219	380	863	1417	2176	3036
13.0	115	231	400	907	1489	2286	3189
14.0	120	241	418	949	1559	2393	3339
15.0	125	252	437	991	1627	2498	3486

Flow Capacity Calculation

Flow capacity values listed above are based on full open valves at 100% overpressure. Read the flow capacity at 100% overpressure directly from the table above. Use linear interpolation if the set pressure is not listed. If the allowable overpressure is less than 100%, modify the flow capacity using the appropriate "C" factor from the table. If allowable overpressure is more than 100%, consult your Groth Representative.

Calculate the percentage overpressure by the following formula. Note that all pressures are gauge pressure expressed in the same units of measure.

P_f = Flowing pressure

P_s = Set pressure

$$\% \text{ OP} = [(P_f - P_s) / P_s] \times 100$$

Calculate flow capacity at less than 100% overpressure according to the following example.

Example Flow Capacity Calculation

6" Model 1261A

4 psig Set Pressure [P_s]

7 psig Flowing Pressure [P_f]

1. Read flow capacity at set pressure from table Flow = 448,000 SCFH

2. Calculate overpressure % OP = [(7 - 4) / 4] x 100 = 75%

3. Read "C" factor from table "C" = 0.83

4. Calculate flow capacity Flow = 0.83 x 448,000 = 371,840 SCFH

"C" Factor Table										
%OP	0	1	2	3	4	5	6	7	8	9
10	*** Consult Factory***									
20	0.27	0.29	0.30	0.32	0.33	0.35	0.36	0.38	0.39	0.40
30	0.42	0.43	0.44	0.45	0.47	0.48	0.49	0.50	0.51	0.52
40	0.53	0.54	0.55	0.56	0.57	0.58	0.59	0.60	0.61	0.62
50	0.63	0.64	0.65	0.66	0.67	0.67	0.68	0.69	0.70	0.71
60	0.72	0.72	0.73	0.74	0.75	0.76	0.76	0.77	0.78	0.79
70	0.80	0.80	0.81	0.82	0.82	0.83	0.84	0.85	0.85	0.86
80	0.87	0.87	0.88	0.89	0.90	0.90	0.91	0.92	0.92	0.93
90	0.94	0.94	0.95	0.96	0.96	0.97	0.97	0.98	0.99	1.00

Example to find "C" factor from table:

Read "C" factor for 75% overpressure at intersection of row 70 and column 5

"C" factor at 75% OP = 0.83

MODEL 1261A PRESSURE RELIEF CAPACITY

Air Flow Capacity at 100% Overpressure (Double Set Pressure)
1000 Normal Cubic Meters per Hour at 0° C

Set Pressure (P _s)	Size In (mm)						
barg	2 (50)	3 (80)	4 (100)	6 (150)	8 (200)	10 (250)	12 (300)
0.07	0.82	1.57	2.72	6.16	10.1	15.5	21.7
0.10	0.99	1.89	3.28	7.45	12.2	18.8	26.2
0.15	1.23	2.36	4.09	9.28	15.2	23.4	32.6
0.20	1.43	2.76	4.80	10.9	17.9	27.4	38.3
0.25	1.62	3.14	5.44	12.3	20.3	31.1	43.4
0.30	1.79	3.48	6.04	13.7	22.5	34.5	48.2
0.35	1.95	3.81	6.61	15.0	24.6	37.8	52.7
0.40	2.10	4.12	7.14	16.2	26.6	40.9	57.0
0.45	2.25	4.41	7.66	17.4	28.5	43.8	61.1
0.50	2.39	4.70	8.16	18.5	30.4	46.6	65.1
0.55	2.52	4.98	8.64	19.6	32.2	49.4	68.9
0.60	2.65	5.25	9.10	20.6	33.9	52.1	72.6
0.70	2.89	5.76	10.0	22.7	37.2	57.2	79.7
0.80	3.13	6.25	10.8	24.6	40.4	62.1	86.5
0.90	3.35	6.72	11.7	26.5	43.5	66.7	93.1
1.00	3.56	7.18	12.5	28.3	46.4	71.2	99.4

Flow Capacity Calculation

Flow capacity values listed above are based on full open valves at 100% overpressure. Read the flow capacity at 100% overpressure directly from the table above. Use linear interpolation if the set pressure is not listed. If the allowable overpressure is less than 100%, modify the flow capacity using the appropriate "C" factor from the table. If allowable overpressure is more than 100%, consult your Groth Representative.

Calculate the percentage overpressure by the following formula. Note that all pressures are gauge pressure expressed in the same units of measure.

$$P_f = \text{Flowing pressure}$$

$$P_s = \text{Set pressure}$$

$$\% \text{ OP} = [(P_f - P_s) / P_s] \times 100$$

Calculate flow capacity at less than 100% overpressure according to the following example.

Example Flow Capacity Calculation

6" Model 1261A

0.4 barg Set Pressure [P_s]

0.7 barg Flowing Pressure [P_f]

1. Read flow capacity at set pressure from table
2. Calculate overpressure
3. Read "C" factor from table
4. Calculate flow capacity

Flow = 16,200 NCMH

$$\% \text{ OP} = [(0.7 - 0.4) / 0.4] \times 100 = 75\%$$

"C" = 0.83

$$\text{Flow} = 0.83 \times 16,200 = 13,446 \text{ NCMH}$$

"C" Factor Table

%OP	0	1	2	3	4	5	6	7	8	9
10	*** Consult Factory***									
20	0.27	0.29	0.30	0.32	0.33	0.35	0.36	0.38	0.39	0.40
30	0.42	0.43	0.44	0.45	0.47	0.48	0.49	0.50	0.51	0.52
40	0.53	0.54	0.55	0.56	0.57	0.58	0.59	0.60	0.61	0.62
50	0.63	0.64	0.65	0.66	0.67	0.67	0.68	0.69	0.70	0.71
60	0.72	0.72	0.73	0.74	0.75	0.76	0.76	0.77	0.78	0.79
70	0.80	0.80	0.81	0.82	0.82	0.83	0.84	0.85	0.85	0.86
80	0.87	0.87	0.88	0.89	0.90	0.90	0.91	0.92	0.92	0.93
90	0.94	0.94	0.95	0.96	0.96	0.97	0.97	0.98	0.99	1.00

Example to find "C" factor from table:

Read "C" factor for 75% overpressure at intersection of row 70 and column 5

"C" factor at 75% OP = 0.83

HOW TO ORDER

For easy ordering, select proper model numbers

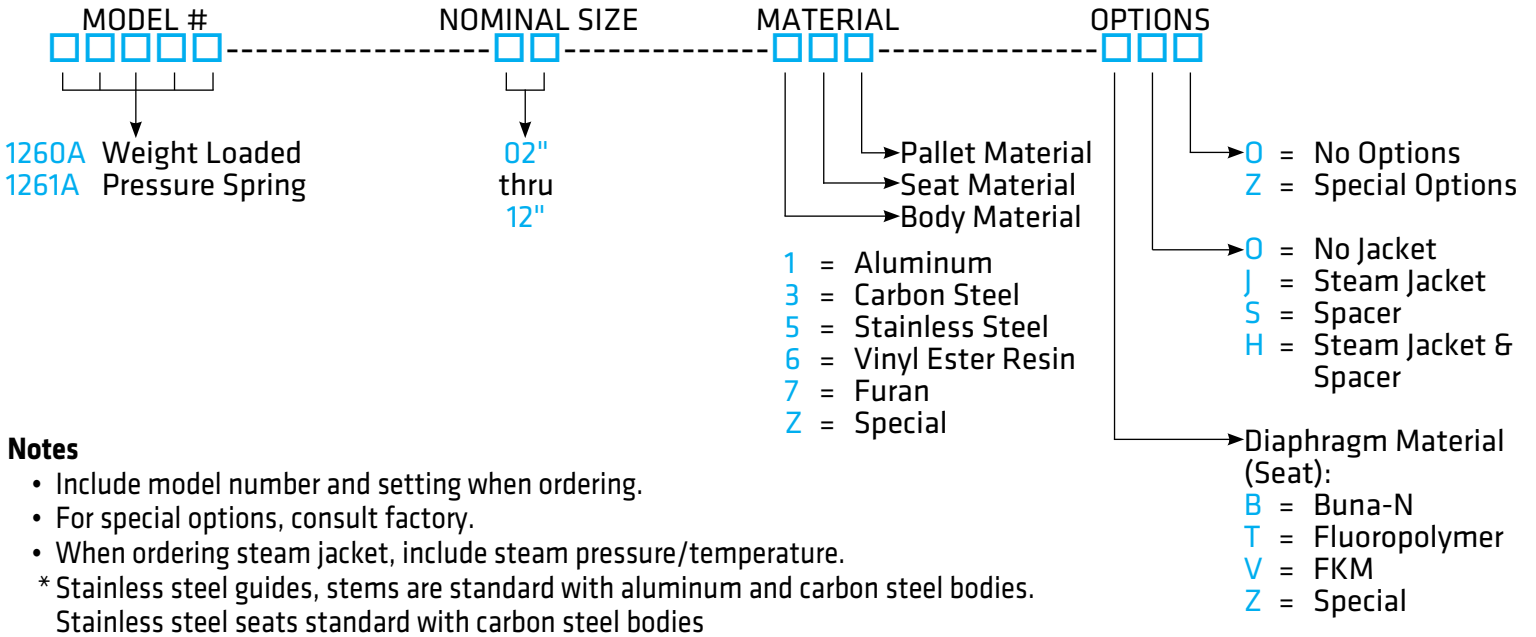

Notes

- Include model number and setting when ordering.
- For special options, consult factory.
- When ordering steam jacket, include steam pressure/temperature.
- * Stainless steel guides, stems are standard with aluminum and carbon steel bodies.
Stainless steel seats standard with carbon steel bodies

Example

1 2 6 0 A - 0 2 - 1 1 5 - T 0 0

Indicates a 2" Model 1260A with Aluminum Body and Seat, Stainless Steel Pallet, Fluoropolymer Seat Diaphragm, and no other options.



GROTHCORP.COM